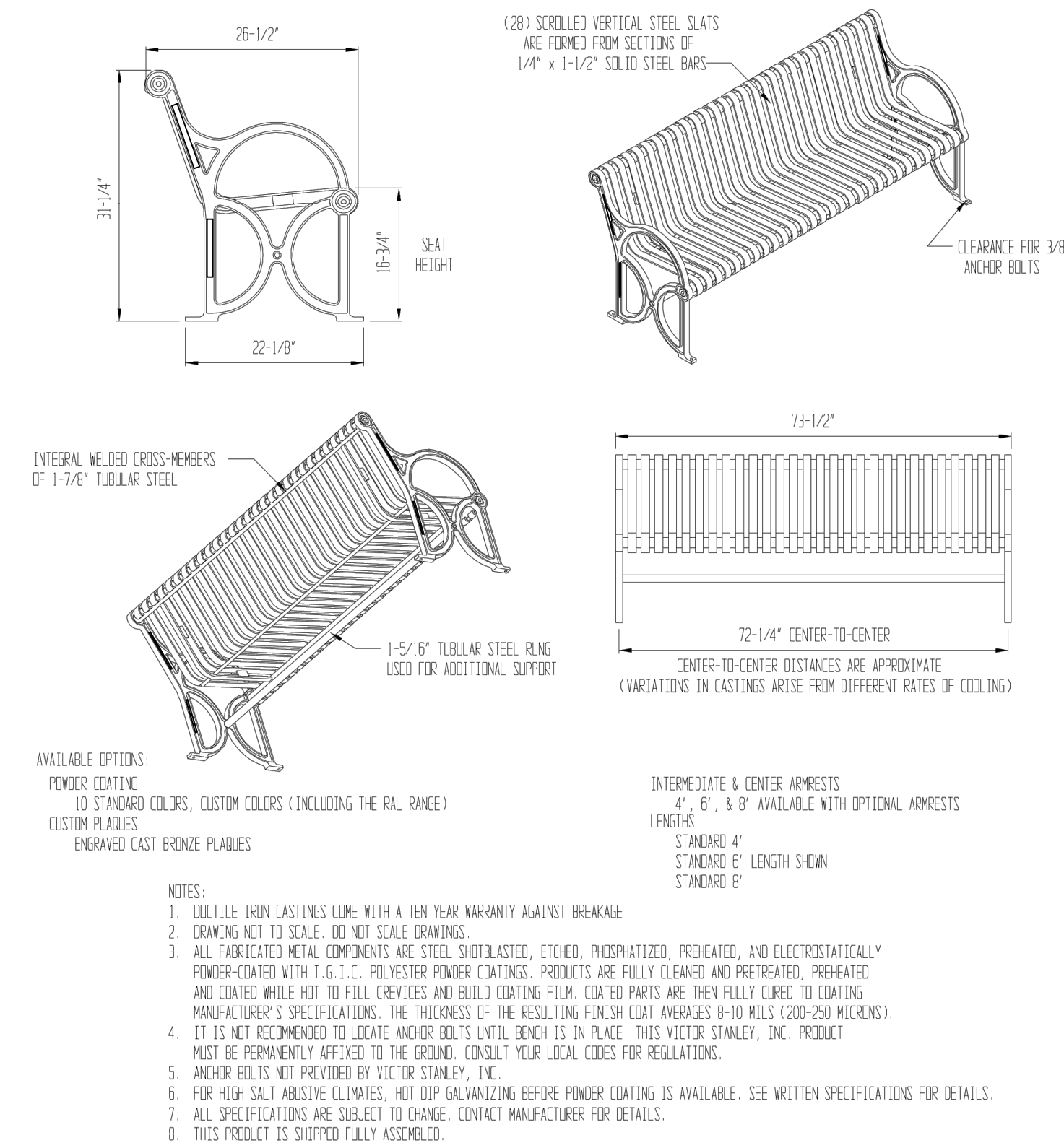
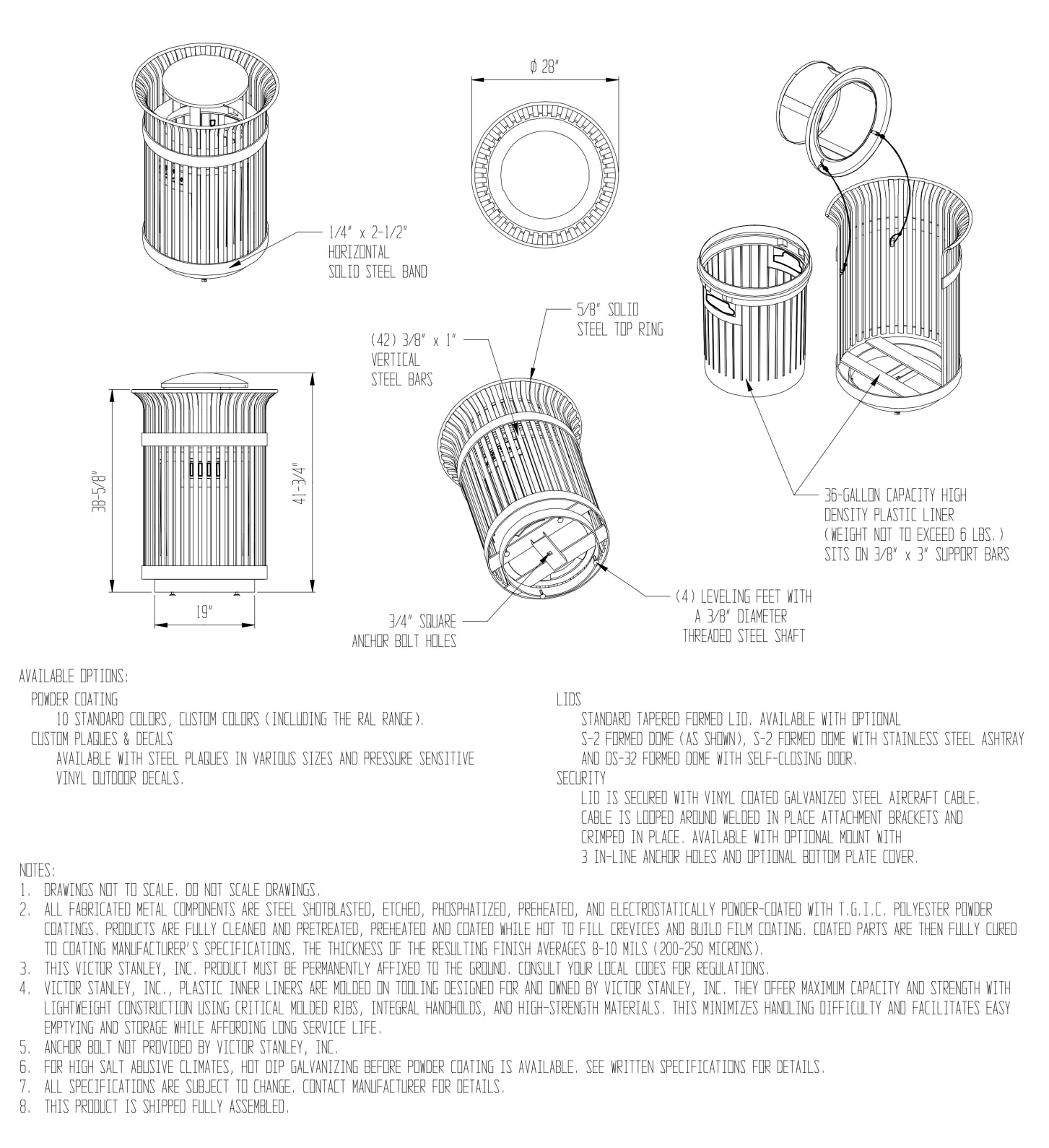

EXHIBIT R



1 **DETAIL - BENCH**
SCALE: N.T.S.



2 **DETAIL - TRASH RECEPTACLE**
SCALE: N.T.S.

TRASH RECEPTACLE				
MANUFACTURER	MODEL #	SIZE	FINISH	COLOR
VICTOR STANLEY	S-42	36 GALLON	STD. 8-10 MM THICK POWDER COATED	VS-BLACK
MAGLIN	MLWR200	32 GALLON	STD. 8-10 MM THICK POWDER COATED	BLACK
LANDSCAPE FORMS	SCARBOROUGH	30 GALLON	STD. 8-10 MM THICK POWDER COATED	BLACK

*OR DEPARTMENT APPROVED EQUAL

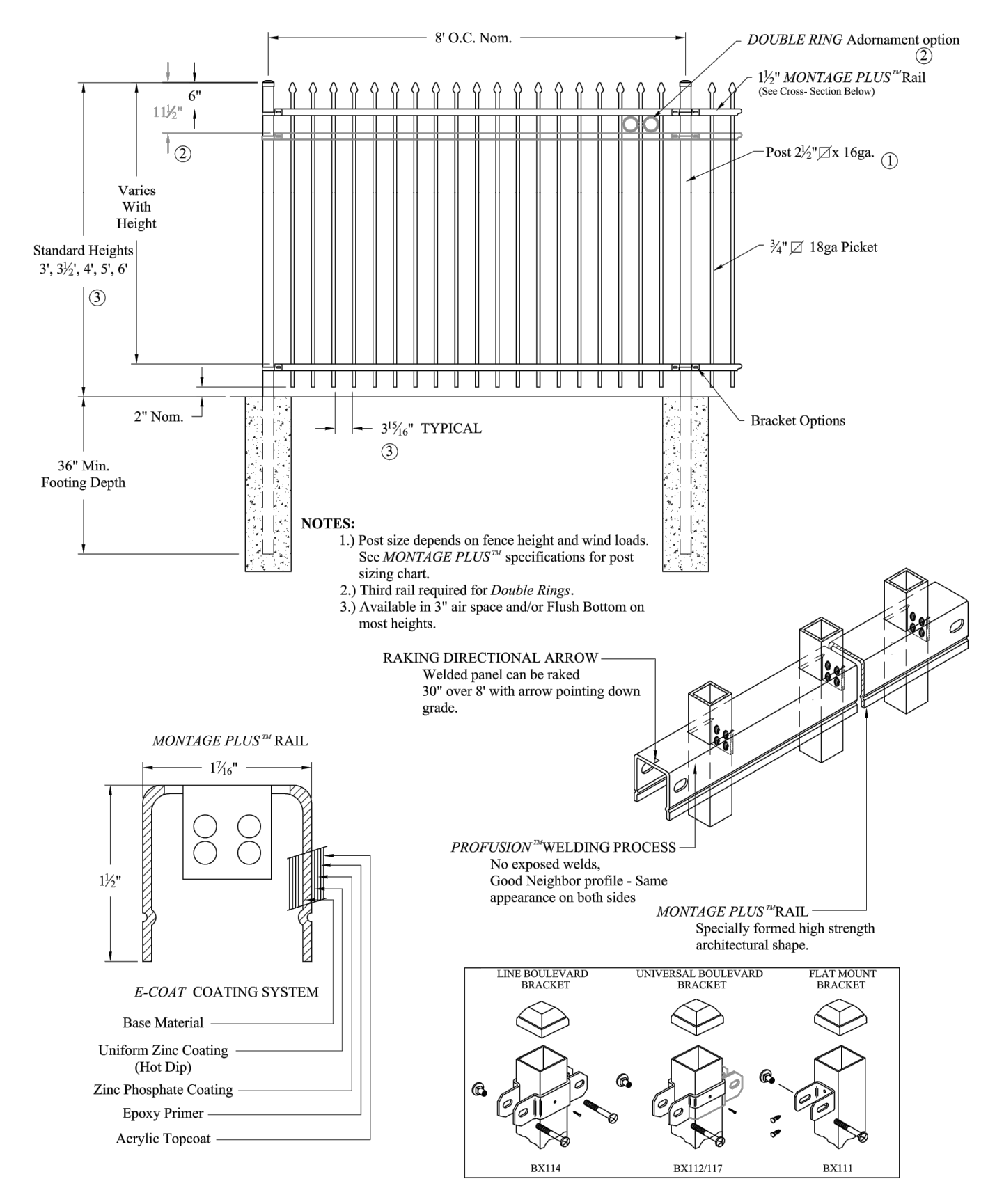

3 **DETAIL - DECORATIVE FENCE**
SCALE: N.T.S.

TRASH RECEPTACLE				
MANUFACTURER	MODEL #	SIZE	FINISH	COLOR
AMERISTAR	MONTAGE PLUS CLASSIC	48"	E-COAT™ PROTECTIVE FINISH	BLACK
INTEGRITY	BELLA VISTA PREMIER	48"	THE LifeCoat™ POWDER COATING	BLACK
JERITH	BUCKINGHAM	48"	FencCoat® POWDER COATING	BLACK

*OR DEPARTMENT APPROVED EQUAL

BENCH				
MANUFACTURER	MODEL #	SIZE	FINISH	COLOR
VICTOR STANLEY	CR-18	6'	STD. 8-10 MM THICK POWDER COATED	VS-BLACK
MAGLIN	MLB590	70"	STD. 8-10 MM THICK POWDER COATED	BLACK
LANDSCAPE FORMS	SCARBOROUGH	72"	STD. 8-10 MM THICK POWDER COATED	BLACK

*OR DEPARTMENT APPROVED EQUAL